

REVISIONS

| ISS | SYMBOL | DESCRIPTION\DATE                                     |
|-----|--------|--|
| B1  |        | 依據設計變更通知單 TA-100-090930AC01 更換 FERRULE 材質 \10/26/09' |

REMARK: RoHS COMPLIANT  
(符合 RoHS)

FOR CUSTOMER

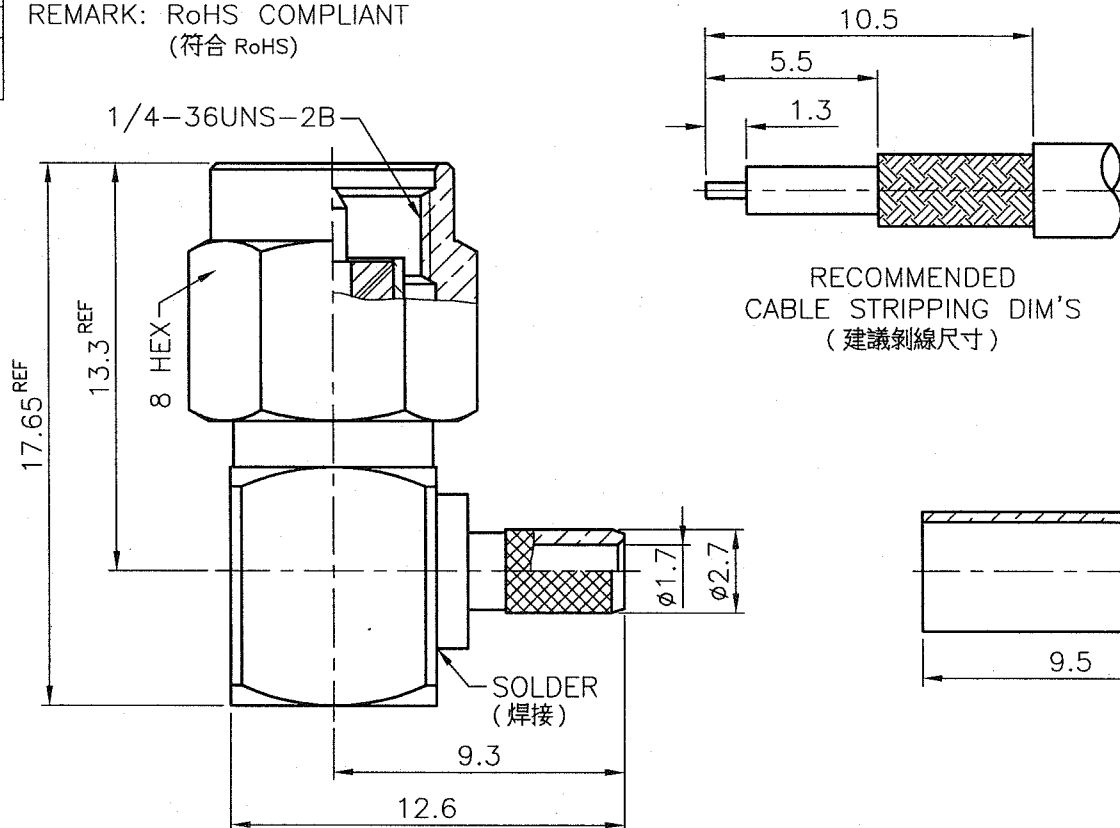

RECOMMENDED  
CABLE STRIPPING DIM'S  
(建議剝線尺寸)

NOTES: FINISH (PLATING THICKNESS IN MICRO-INCHES)

1. BRASS PER QQ-B-626
2. GOLD PL 3 MIN OVER NICKEL PL 70 MIN THICK OVER COPPER STRIKE
3. GOLD PL 30 MIN OVER NICKEL PL 70 MIN THICK OVER COPPER STRIKE
4. TEFLON MIL-P-19468
5. BERYLLIUM COPPER PER QQ-C-530
6. COPPER JIS H 3300,C 1220

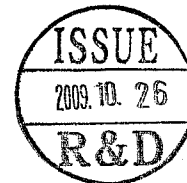
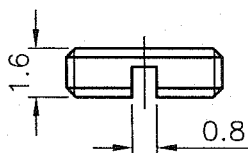

1. CRIMPED FERRULE  
HEX CRIMP SIZE .128" (3.25mm)  
(套管壓著工具)
2. CONTACT PIN TO SOLDER  
(中心針銲接)

| NO. | DESCRIPTION | MATERIAL | FINISH | Q'TY   | DRAWING NO. | SCALE | 4/1 | ISSUE | B1 |
|-----|-------------|----------|--------|--------|-------------|-------|-----|-------|----|
|     | COVER       |          | NOTE 1 | NOTE 2 |             |       |     |       |    |
|     | FERRULE     |          | NOTE 6 | NOTE 2 |             |       |     |       |    |
|     | SHELL       |          | NOTE 1 | NOTE 2 |             |       |     |       |    |
|     | GASKET      | SILICONE |        | RED    |             |       |     |       |    |
|     | C RING      |          | NOTE 5 | NONE   |             |       |     |       |    |
|     | CONTACT PIN |          | NOTE 1 | NOTE 3 |             |       |     |       |    |
|     | INSULATOR   |          | NOTE 4 | WHITE  |             |       |     |       |    |
|     | MAIN BODY   |          | NOTE 1 | NOTE 2 |             |       |     |       |    |

DIMENSIONS ARE IN MILLIMETERS  
UNLESS OTHERWISE SPECIFIED  
TOLERANCES  
(一般公差)  
0.5~6 = ±0.2  
>6~30 = ±0.4  
>30~120 = ±0.6  
>120~315 = ±1  
>315~1000 = ±1.6  
ANGLES(角度) = ±5'

| PART NO. |           |
|----------|-----------|
| APPROVED | DATE      |
| ARK      | 10/26/09' |
| CHECKED  | DATE      |
| ARK      | 10/26/09' |
| DRAWN    | DATE      |
| Arnel    | 10/26/09' |

**BO-JIANG** 帛江科技股份有限公司  
BO-JIANG TECHNOLOGY CO., LTD.

TITLE  
SMA R/A CRIMP PLUG  
(FOR RG-174/U,188A/U,316/U)

DRAWING NO.  
**7811NR509BD003B**

FILE NO. Z:\NND\7811\NR\509\003\7811NR509BD003B-B1