

REVISIONS		
ISS	SYMBOL	DESCRIPTION\DATE
A1		由BJ-7804-02BGTG-R 型號轉來\08/02/06'

REMARK: RoHS COMPLIANT  
(符合 RoHS)

FOR CUSTOMER

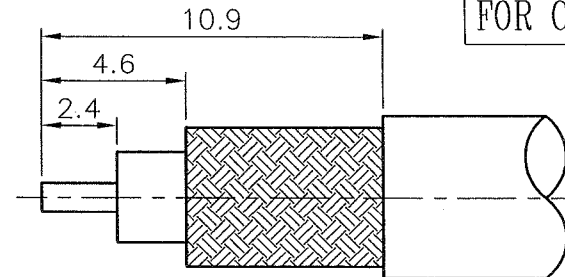
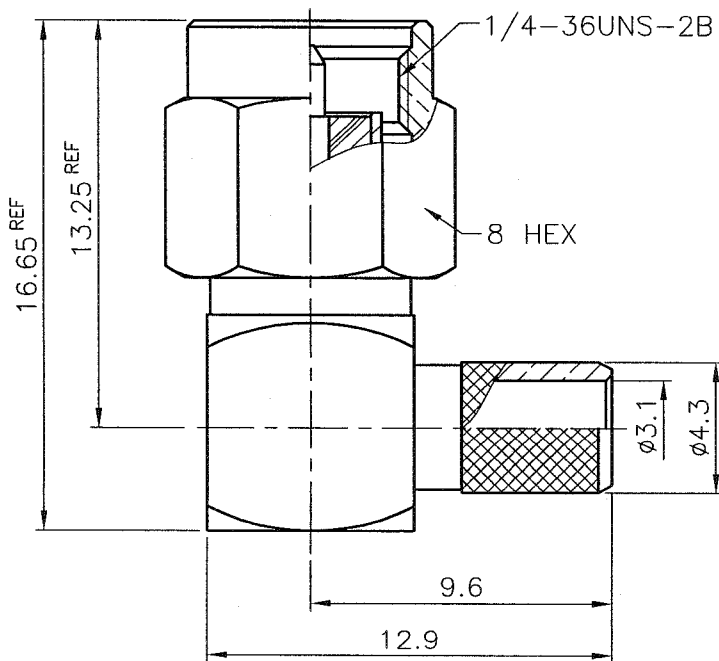

RECOMMENDED  
CABLE STRIPPING DIM'S  
(建議剝線尺寸)

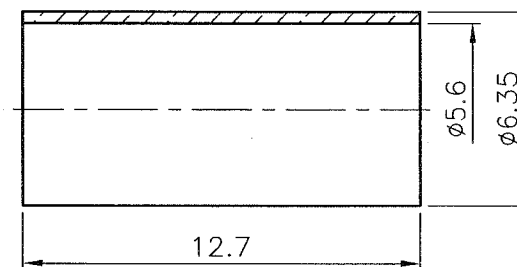

NOTES: FINISH (PLATING THICKNESS IN MICRO-INCHES)

1. BRASS PER QQ-B-626
2. GOLD PL 3 MIN OVER NICKEL PL 70 MIN THICK OVER COPPER STRIKE
3. GOLD PL 30 MIN OVER NICKEL PL 70 MIN THICK OVER COPPER STRIKE
4. TEFLON MIL-P-19468
5. BERYLLIUM COPPER PER QQ-C-530
6. BRASS JIS H 3250, C 2700
7. BRASS PER QQ-B-613

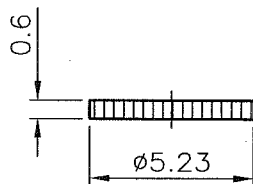

1. CRIMPED FERRULE  
HEX CRIMP SIZE .213" (5.41mm)  
(套管壓著工具)
2. CONTACT PIN TO SOLDER  
(中心針銲接)

NO.	DESCRIPTION	MATERIAL	FINISH	Q'TY	DRAWING NO.
	COVER	NOTE 7	NOTE 2		
	FERRULE	NOTE 6	NOTE 2		
	SHELL	NOTE 1	NOTE 2		
	GASKET	SILICONE	RED		
	C RING	NOTE 5	NONE		
	CONTACT PIN	NOTE 1	NOTE 3		
	INSULATOR	NOTE 4	WHITE		
	BODY	NOTE 1	NOTE 2		

DIMENSIONS ARE IN MILLIMETERS

UNLESS OTHERWISE SPECIFIED  
TOLERANCES

- (一般公差)
- 0.5~6 = ±0.2
  - >6~30 = ±0.4
  - >30~120 = ±0.6
  - >120~315 = ±1
  - >315~1000 = ±1.6
  - ANGLES(角度) = ±5'

PART NO.

APPROVED *Aark* DATE 08/02/06'

CHECKED *Aark* DATE 08/02/06'

DRAWN *Anel* DATE 08/02/06'

**BO-JIANG** 帛江科技股份有限公司  
BO-JIANG TECHNOLOGY CO., LTD.

TITLE  
SMA R/A CRIMP PLUG  
(FOR RG-55/U,142A/U,223/U,400/U)

DRAWING NO. 7811NR502BD000B

FILE NO. Z:\NND\7811\NR\502\000\BDB-A1